

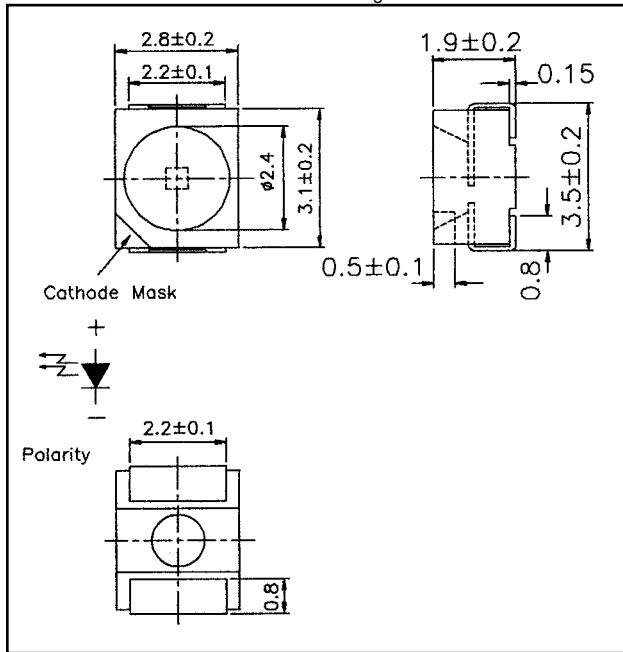

Weight: 2.0 Unit: mm



AND6BA

GaN Ultra Bright Blue Light Emission Surface Mount Pkg

Features

• RoHS Compliant

- P-LCC-2 package with optical indicator
- Wide viewing angle
- Suitable for vapor-phase reflow, infrared reflow and wave solder processes
- Low current operation: 2 mA
- Ideal for (LCD) backlight & light pipe applications
- Compatible with automatic placement equipment

Maximum Ratings (T_a = 25°C)

Characteristics	Symbol	Rating	Unit
Forward Current	I _F	30	mA
Reverse Voltage	V _R	5	V
Power Dissipation	P _D	120	mW
Operating Temperature Range	T _{Opr}	-20 to 80	°C
Storage Temperature Range	T _{Stg}	-30 to 90	°C

Product specifications contained herein may be changed without prior notice. It is therefore advisable to contact Purdy Electronics before proceeding with the design of equipment incorporating this product.

Electro-Optical Characteristics (T_a = 25°C)

Characteristics	Symbol	Test Condition	Minimum	Typical	Maximum	Unit
Forward Voltage	V _F	I _F = 20 mA	–	3.8	4.5	V
Reverse Current	I _R	V _R = 5 V	–	–	50	μA
Luminous Intensity	I _V	I _F = 20 mA	35	55	–	mcd
Peak Emission Wavelength	I _P	I _F = 20 mA	–	428	–	nm
Spectral Line Half Width	ΔI	I _F = 20 mA	–	65	–	nm
Dominant Wavelength	I _d	I _F = 20 mA	–	466	–	nm
Full Viewing Angle	2 q 1/2	I _F = 20 mA	–	120	–	degree

Precaution

Please be careful of the following:

1. Manual soldering: maximum temperature of iron tip: 260°C max.
Soldering time: within 5 sec. per solder-land
Soldering portion of lead: up to 1.6 mm from the body of the device
2. Reflow solder: recommended condition is as follows:

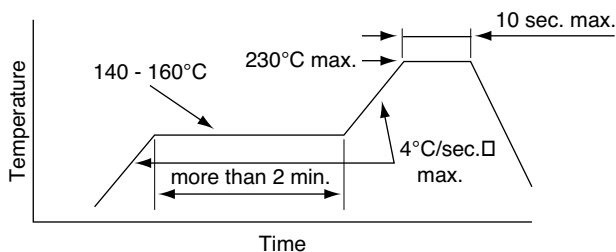

3. Absolute secure counter measures against static electricity and surge should be taken when handling these products. It is recommended to use wrist band or antistatic gloves when handling these LEDs.

For reflow soldering

